

> GAMME ASME BPE

- Coudes à 45° - 90° & 180°

→ DT-4.1.1-1 (ex DT-7)

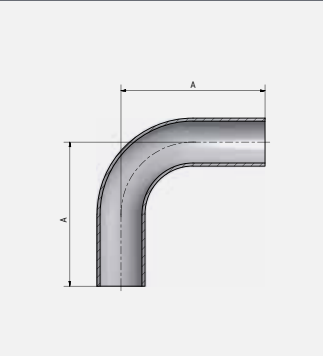

→ DT-4.1.1-2 (ex DT-12)

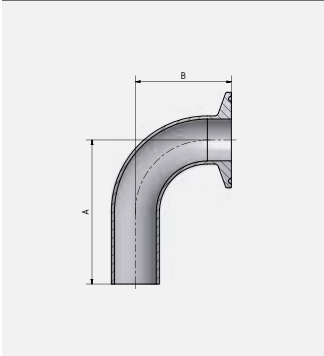

→ DT-4.1.1-3 (ex DT-16)

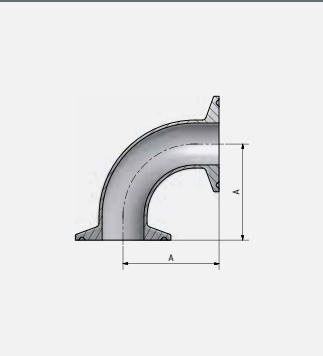

→ DT-4.1.1-4 (ex DT-8)



→ DT-4.1.1-5 (ex DT-13)

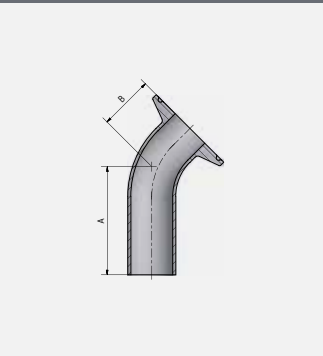

→ DT-4.1.1-6 (ex DT-17)

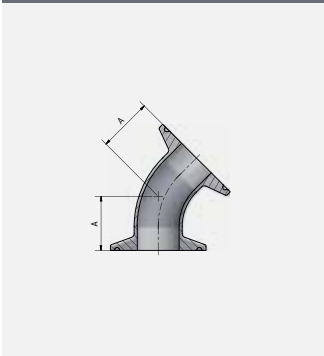

→ DT-4.1.1-7 (ex DT-23)

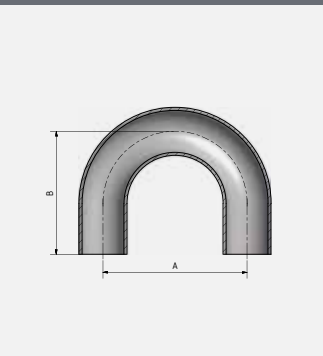

→ DT-4.1.1-8 (ex DT-24)

