

Specification Sheet

NovAseptic® Mixer, Tank Plate, GMP and HS

Product Description

The NovAseptic® mixers offer a complete solution for mixing throughout the process line and are designed for a wide variety of mixing applications in the pharmaceutical and biotechnology industries.

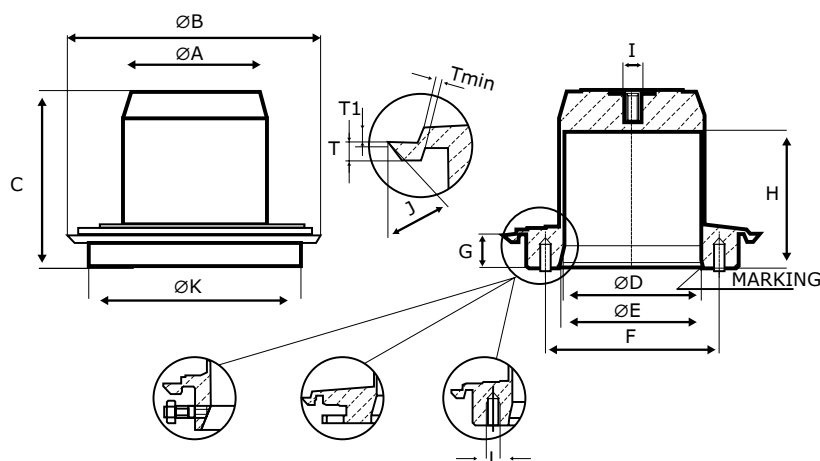

Catalogue No. Structure

GM#/33

= Size
GM = Mixer
33 = Welded Tank Plate

Nominal Dimensions in mm (in.)

Catalogue No.	A	B	C	D	E	F	G	H	I	J	K	L	T	T1	Tmin	Compatible Mixer
GM05/33	32 (1.26)	72 (2.83)	56 (2.20)	28 (1.10)	—	—	18 (0.71)	44 (1.73)	M6	45°	50 (1.97)	—	3 (0.12)	1 (0.04)	2.5 (0.10)	GMP 50, HS T10 & USM T10
GM1/33	54 (2.13)	90 (3.54)	58 (2.28)	50 (1.97)	—	—	19 (0.75)	46 (1.81)	M6	45°	64 (2.52)	—	4 (0.16)	1 (0.04)	1.8 (0.07)	GMP100
GM5/33	54 (2.13)	90 (3.54)	68 (2.68)	50 (1.97)	—	—	19 (0.75)	56 (2.20)	M6	45°	64 (2.52)	—	4 (0.16)	1 (0.04)	1.8 (0.07)	GMP500
GM10/33	62 (2.44)	150 (5.91)	69 (2.72)	58 (2.28)	65 (2.56)	110 (4.33)	17 (0.67)	56 (2.20)	M6	45°	125 (4.92)	—	4 (0.16)	1 (0.04)	2.2 (0.09)	GMP1000
GM20/33	85 (3.35)	150 (5.91)	73 (2.87)	81 (3.19)	85 (3.35)	110 (4.33)	20 (0.79)	58 (2.28)	M10	45°	125 (4.92)	—	4 (0.16)	1 (0.04)	2.3 (0.09)	GMP2000
GM50/33	104 (4.09)	160 (6.30)	73 (2.87)	100 (3.94)	104 (4.09)	116 (4.57)	13 (0.52)	54 (2.13)	M12	45°	128 (5.04)	M8	6 (0.24)	1.5 (0.06)	4.2 (0.17)	GMP5000
GM100/33	85 (3.35)	150 (5.91)	105 (4.13)	81 (3.19)	85 (3.35)	105 (4.13)	20 (0.79)	81 (3.19)	M12	45°	125 (4.92)	M8	5 (0.20)	1 (0.04)	2.4 (0.09)	GMP10000
GM200/33	168 (6.61)	240 (9.45)	94 (3.70)	164 (6.46)	168 (6.61)	187 (7.36)	25 (0.98)	69 (2.72)	M12	45°	207 (8.15)	M10	6 (0.24)	1 (0.04)	5.4 (0.21)	GMP20000
GM300/33	168 (6.61)	240 (9.45)	119 (4.69)	164 (6.46)	168 (6.61)	187 (7.36)	29 (1.14)	94 (3.70)	M12	30°	207 (8.15)	M10	12 (0.47)	2 (0.08)	7.8 (0.31)	GMP30000

Specifications

Net Weight (approximate)									
Tank Plate	GM05/33	GM1/33	GM5/33	GM10/33	GM20/33	GM50/33	GM100/33	GM200/33	GM300/33
Weight kg (lb)	0.5 (1.1)	0.5 (1.1)	0.6 (1.3)	2 (4.4)	2 (4.4)	2.5 (5.51)	3 (6.6)	8 (18)	8 (18)

Welding Diameter									
Tank Plate	GM05/33	GM1/33	GM5/33	GM10/33	GM20/33	GM50/33	GM100/33	GM200/33	GM300/33
Diameter mm (in.)	Ø72 (Ø2.83)	Ø90 (Ø3.54)	Ø90 (Ø3.54)	Ø150 (Ø5.91)	Ø150 (Ø5.91)	Ø160 (Ø6.30)	Ø150 (Ø5.91)	Ø240 (Ø9.45)	Ø240 (Ø9.45)

Material		
Bar Stainless Steel in Compliance with		
Material Code	316L	EN 1.4435
Technical Requirements	ASME® SA-479	EN 10272

Specifications	
Surface Roughness	Surface Ra ≤ 0.38 µm (15 µin)
Surface Treatment	Liquid contact surface, manually polished. No polishing compounds of animal origin used.
Design Temperature, Tank Plate*	-80 to 200 °C (-112 to 392 °F)
Design Pressure, Tank Plate*	-1.03 to 10 bar(g) (-15 to 145 psi(g))
Labeling	Each Tank Plate is individually labeled for full traceability and heat No. according to our procedures.
Packaging	The tank plate is packaged in a closed box.
Quality Control	Our Quality Assurance System guarantees the control and traceability at all stages of the manufacturing.
Liquid viscosity	1 to 800 cP max
Regulatory	The Tank Plate is designed to meet requirements for USA, ASME VIII Div 2. Stresses in Tank Plate due to internal pressure have been analyzed by FEM. The NovAseptic® Tank plate is not in the scope of the PED directive 2014/68/UE. However they have been designed and evaluated for assembly by welding at a bottom of a vessel with a max allowable pressure of 10 bar and a max allowable temperature of 200 °C.
Options	For non-standard NovAseptic® Mixer Options, please contact us for further information.

* The assembled NovAseptic® Mixer may have different design temperature and/or pressure limits. The weakest component in the assembled product determines

Technical Assistance

For more information, please visit SigmaAldrich.com for up-to-date worldwide contact information

