

Specification Sheet

NovAseptic® Mixer, Multi-Purpose Tank Base, (MPTB)

Base with Integrated Tank Plate and Outlet Valve

The MPTB is offered as a component for constructing small, bench-top or pilot-scale mixing vessels for critical pharmaceutical and biotech mixing applications. To meet your processing requirements the tank base may be fitted with low, medium or high shear type mixers. The MPTB is designed to exceed the most stringent performance demands of the pharmaceutical manufacturing industry. Manufactured from a single piece of solid bar stock, it incorporates the magnetic mixer tank plate and TOV outlet valve body. The base may be used to construct vessels small enough to facilitate the mixing of volumes as small as 0.8 L. The unit provides complete drain ability and can be cleaned in place.

Configuration

A standard NovAseptic® TOV valve is fitted to the bottom of the base to suit your process requirements. Valve sizes ranging from 1/2 in. to 1 in. may be selected to ensure quick draining of the solutions. Standard valve diaphragms and manual actuators may be inserted into the valve body. The MPTB may be used with either a SST or plastic tubing for the vessel wall. For non stainless applications, a large TC connection may be fitted to the base to enable attached of plastic or glass tubes. Depending on the length of the tube attached to the vessel, mixing volumes may range from 12 to 60 L. This configuration allows for volumes as low as 1 L to be mixed using a NovAseptic® mixer.

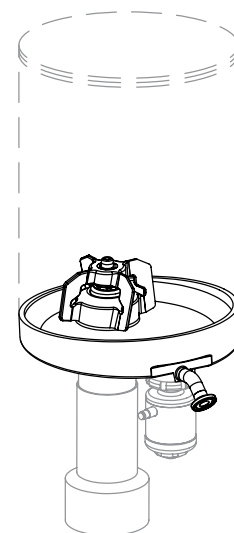
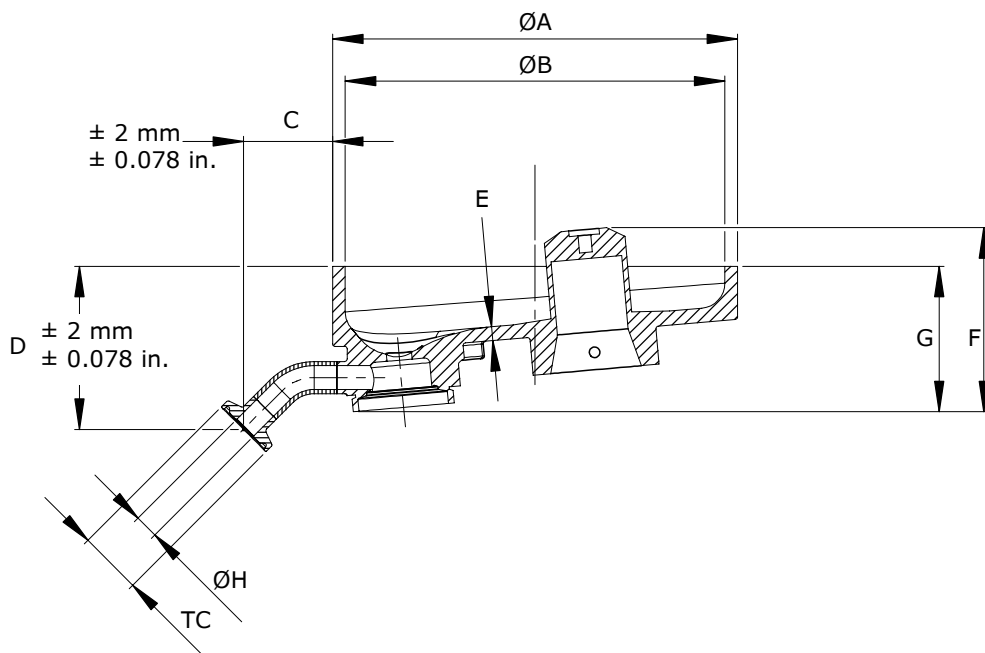

Nominal Dimensions in in. (mm)

Part No.	General Dimensions									Integrated Components		Mixer Type (shear)		
	Ø A	Ø B	C	D	E	F	G	Ø H	TC	Valve	Tank Plate	Low	Medium	High
MPTB05050150-312	6.3 (160)	5.91 (150)	1.385 (35)	2.54 (64)	0.217 (5.5)	2.862 (73)	2.262 (57)	0.370 (9.4)	0.984 (25)	NU050/442-312	GM05/33	GMP 50	USMT10*	HST10*
MPTB05075200-312	8.27 (210)	7.87 (200)	2.737 (69.5)	3.28 (83.2)	0.217 (5.5)	3.296 (84)	2.696 (68)	0.622 (15.8)	0.984 (25)	NU075/442-312	GM05/33	GMP 50	USMT10	HST10
MPTB05100250-312	10.24 (260)	9.84 (250)	2.251 (57)	3.71 (94)	0.217 (5.5)	3.884 (99)	3.683 (83)	0.870 (22.1)	1.988 (50.5)	NU100/442-312	GM05/33	GMP 50	USMT10	HST10
MPTB05100300-312	12.2 (310)	11.8 (300)	1.910 (48.5)	3.79 (96.4)	0.217 (5.5)	3.969 (101)	3.368 (86)	0.870 (22.1)	1.988 (50.5)	NU100/442-312	GM05/33	GMP 50	—	—
MPTB1100300-312	12.2 (310)	11.8 (300)	1.910 (48.5)	3.79 (96.4)	0.276 (7)	4.07 (102)	3.364 (85)	0.870 (22.1)	1.988 (50.5)	NU100/442-312	GM1/33	GMP 100	—	—

* Please note that the following actuator catalog numbers are not compatible in this configuration: PA12/111, PA12/100 and FA12/154

Select the Right Mixer For Your Application

The MPTB base can be fitted with either a low, medium or high shear mixer. This allows for maximum flexibility in configuring the mixing vessel for your application. Simply install the correct mixing head and drive unit and the vessel is ready to use. Should you require more power for your application select a MPTB where a larger GMP mixer can be attached.

Product Recovery

To ensure all of the product is recovered, the bottom of the base has a sloped cavity that is tilted towards the drainage port. This ensures all of the liquid is pitched towards the drain valve, maximizing product recovery. Any liquid that remains in the vessel is due to liquid adhesion. If high viscosity liquids are to be mixed, select the proper size valve to ensure quick draining after processing.

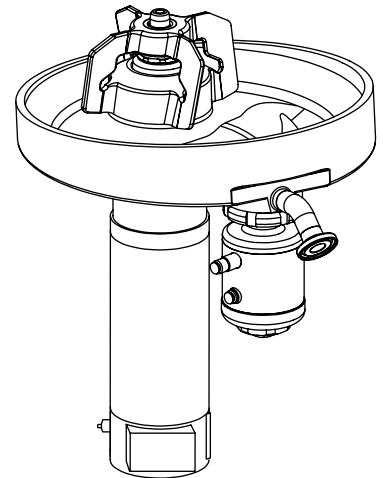
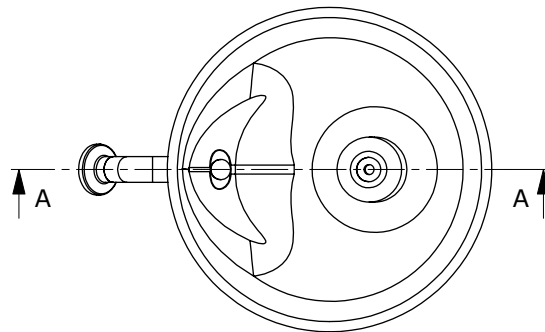
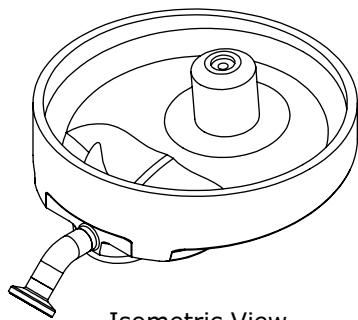

Specifications

Surface Roughness	Surface Ra <0.38 µm (15 µin),	
Operating Temperature*	5 to 200 °C (41 to 392 °F)	
pH Range	1–14	
Pressure Rating	Part No.	Design Pressure, bar (psig)
	MPTB05050150-312	8 (116)
	MPTB05075200-312	6 (87)
	MPTB05100250-312	4 (58)
	MPTB05100300-312	4 (58)
	MPTB1100300-312	6 (87)
Requirement	The tank bottom is designed in accordance to PED 2014/68/EU. The pressure rating for the MPTB has been determined by FEM.	
Labeling	Each MPTB is individually labeled for full traceability according to QA procedures.	
Packaging	The MPTB is packaged in a closed box.	
Quality Control	Our Quality Assurance system ensures the quality and traceability at all stages of the process.	
* Note	The assembled NovAseptic® MPTB may have different design temperature and/or pressure limits. The weakest part in the assembled product determines the maximum design temperature and pressure limits.	

Technical Assistance

For more information, please visit [SigmaAldrich.com](https://www.SigmaAldrich.com)
for up-to-date worldwide contact information

