

## Specification Sheet

# NovAseptic<sup>®</sup> Mixer, Drive Unit, GMP Explosion proof motor CL Div. 1 GRP C&D T3C

## Product Description

The NovAseptic<sup>®</sup> mixers offer a complete solution for mixing throughout the process line and are designed for a wide variety of mixing applications in the pharmaceutical and biotechnology industries.

Catalogue Number:

GM##/4##1-BEXPM

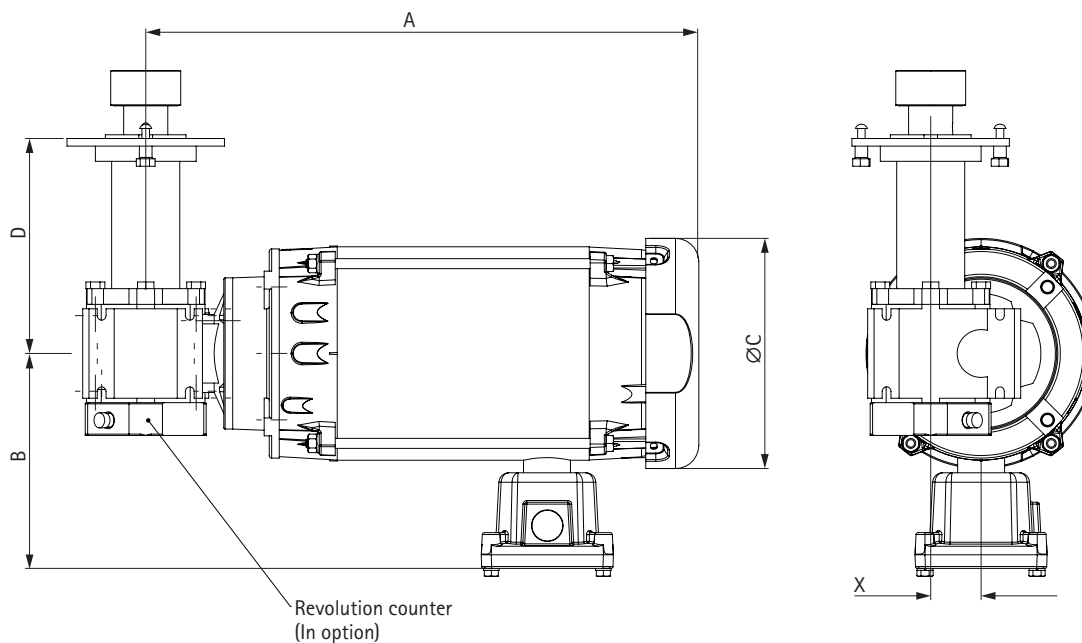

## Catalogue No. Structure

GM

Mixer

#

Size

Surface Treatment

#

Shaft Option

A: Drive Unit, revolution counter compatible  
B: Drive Unit with revolution counter

1: 60 mm extension  
2: 100 mm extension

1

Drive Unit Color

1: Green

BEXPM

Baldor explosion proof motor

## Nominal Dimensions in mm

Mixer Model	A	B	C	D	X	Catalogue No
GMP 50	437	177	183	140	31	GM05/4A11-BEXPM
GMP 50	437	177	183	140	31	GM05/4B11-BEXPM
GMP 100	437	177	183	181	40	GM1/4A21-BEXPM
GMP 100	437	177	183	181	40	GM1/4B21-BEXPM
GMP 500	437	177	183	181	40	GM5/4A21-BEXPM
GMP 500	437	177	183	181	40	GM5/4B21-BEXPM
GMP 1000	438	177	183	171	40	GM10/4A21-BEXPM
GMP 1000	438	177	183	171	40	GM10/4B21-BEXPM
GMP 2000	473	177	183	191	40	GM20/4A21-BEXPM
GMP 2000	473	177	183	191	40	GM20/4B21-BEXPM
GMP 5000	508	177	183	195	40	GM50/4A21-BEXPM
GMP 5000	508	177	183	195	40	GM50/4B21-BEXPM
GMP 20000	582	220	234	218	75	GM200/4A21-BEXPM
GMP 20000	582	220	234	218	75	GM200/4B21-BEXPM
GMP 30000	582	220	234	218	75	GM300/4A21-BEXPM
GMP 30000	582	220	234	218	75	GM300/4B21-BEXPM

## Specifications

### General Motor Data

Voltage	230/460V (usable at 208 V except 5 HP motor)
Number of Poles	2 (except GMP 20000 Et GMP 30000 4 poles)
Color	Green, complies with the Code of Federal Regulations (FDA), US 21 CFR 170-199
Oil	Synthetic, complies with the Code of Federal Regulations (FDA) 21 CFR
Certified	CSA/UL
Explosion proof area	CL D1 GRP C&D T3C

### General Revolution Counter Data

Manufacturer	Pepperl+Fuchs
Catalogue No.	NCB1.5-8GM25-N0-V1
Standard	NAMUR DIN EN 60947-5-6
Labeling	II 1G EEx ia IIC T6, II 1D Ex iaD 20T 108oC
Degree of Protection	IP 67
Pulses/Revolution	1
Cable Length (Detachable)	2m

## Specifications (continued)

### Drive Unit Specifications (motor and frame)

Brand: Baldor	Max Power (HP)		Max Current (A)	
	60 Hz	230 VAC	460 VAC	Frame
GMP50	0.5	1.75	0.75	56C
GMP100	0.5	1.75	0.75	56C
GMP500	0.5	1.75	0.75	56C
GMP1000	1	2.8	1.4	56C
GMP2000	1.5	4	2	145TC
GMP5000	2	5	2.5	145TC
GMP20000	5	12.2	6.1	184C
GMP30000	5	12.2	6.1	184C

### Drive Unit Specifications (gearbox and complete drive unit)

Mixer Size	Type Nord	Gear Box Ratio (i)	Outer Driving Head Torque (Nm)	Design Speed (rpm)*
GMP50	5K1S131	7.5	1	50–490
GMP100	5K1S140	7.5	2	50–490
GMP500	5K1S140	7.5	6	50–490
GMP1000	5K1S140	7.5	8	50–490
GMP2000	5K1S140	7.5	13	50–490
GMP 5000	5K1S140	7.5	26	50–490
GMP20000	5K1S175	5	60	35–335
GMP30000	5K1S175	7.5	150	25–245

### Additional Information

Environment Temperature**	0 to 40 °C (32 to 104 °F)
Design Pressure	Atmospheric pressure
Operating Speed	Maximum operating speed has to be validated for each process individually, depending on volume, viscosity, etc. A variable frequency drive (VFD) must be used with all NovAseptic® mixers.
Labeling	Each drive unit is individually labeled for full traceability according to our QA procedures
Packaging	The drive unit is packaged in a closed box
Quality Control	Our Quality Assurance System guarantees the control and traceability at all stages of the manufacturing process
Options	For non-standard NovAseptic® mixer options, please contact your local sales representative for information

\*Note: Design Speed is the mechanical limit.

\*\*Note: The assembled NovAseptic® Mixer may have different design temperature and/or pressure limits. The weakest part in the assembled product sets the final permitted design temperature and pressure limits.



[www.emdmillipore.com/offices](http://www.emdmillipore.com/offices)

EMD Millipore and the M mark are registered trademarks of Merck KGaA, Darmstadt, Germany. NovAseptic is a registered trademark of Millipore AB. Specifications subject to change without notice. Lit. No. SP5229EN00 Rev. A 07/2014 PS-13-08217 Printed in the USA. ©2014 EMD Millipore Corporation, Billerica, MA 01821 U.S.A. All rights reserved.

## To Place an Order or Receive Technical Assistance

In the U.S. and Canada, call toll-free:  
**1(800)–645–5476**

For other countries across Europe, call:  
**+44 (0) 115 943 0840**

For other countries across Europe and the world, please visit [www.emdmillipore.com/offices](http://www.emdmillipore.com/offices)

For Technical Service, please visit  
[www.emdmillipore.com/techservice](http://www.emdmillipore.com/techservice)